

## Products Features

- ▶ Using special optical lens design to increase the intensity.
- ▶ Compatible with telecentric lens to get good image result.

## Applications the light be used for

- Micro semiconductor products detection.
- Compatible with micro lens.
- LED wafer inspection machine.

## Model Description

SBS-SPL-XXXX-X

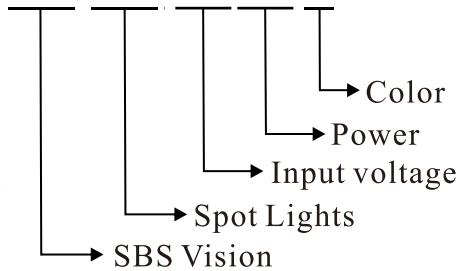

## Customization

- Dimensions
- Color
- Power
- Mounting
- Cable length

## Structure

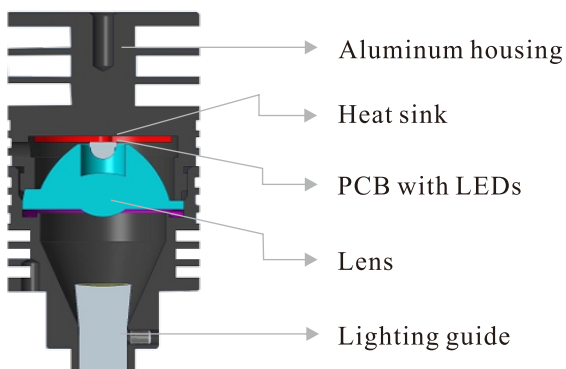

## Components

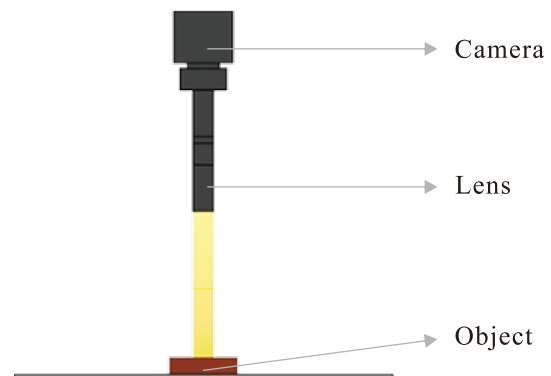

Parameter

Item	Model	Power consumption Red Color	Power consumption (W,B,G)	Option	Extension cable	Recommended Controller
1	SBS-SPL0501	5V/1.0W	5V/1.0W	Diffuser	1m/3m/5m	SBS-AC5 (Analog Controller) SBS-DC5 (Digital Controller)
2	SBS-SPL0503	5V/3.0W	5V/3.0W	Diffuser	1m/3m/5m	
3	SBS-SPL2-0503	5V/3.0W	5V/3.0W	Diffuser	1m/3m/5m	

Dimensions(mm)

